

- According to DIN EN 61810-1, DIN EN 61810-3 (Type A), DIN EN 45545 (fire protection on railway vehicles)
- With forcibly guided contacts
- Safe separation between coil/contact and contact/contact for applications at pollution degree 2 with rated insulation voltage 250 V
- Clearance and creepage distances:
Contact - coil ≥ 5.5 mm
Contact - contact ≥ 5.5 mm
- Low nominal and holding power
- High mechanical service life
- Smallest height with only 10.3 mm
- RoHS compliance
- Placing SMD components between PCB and relay is possible

Applications

- Switchgear for safety technology
- Safety controls
- Escalators and walkways
- Elevators for men and load
- Press controls
- Railway technology

Approvals and Markings

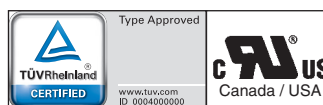

Technical Data

Relay type	OA 5642	OA 5643	OA 5644
1.0 Relay coil			
1.1 Nominal voltage	DC 6; 12; 21; 24; 48; 60; 110 V (others on request)		
1.2 Nominal consumption	0.40 W	0.50 W	0.65 W
1.11 Voltage range	0.7 ... 1.6 U _N	0.7 ... 1.6 U _N	0.7 ... 1.6 U _N
1.12 Thermal resistance		65 \pm 10 K/W	
1.13 Holding power (at 0,5 x U _N)	0.1 W	0.125 W	0.160 W
2.0 Contacts			
2.1 Contact arrangement (Type A)	1 NO / 1 NC	2 NO / 1 NC	2 NO / 2 NC 3 NO / 1 NC
2.2 Contact material	AgSnO ₂ + 0.2 μ m Au; AgNi + 0.2 μ m Au, AgNi + 5 μ m Au		
2.3 Rated insulation voltage	AC 250 V		
Switching voltage min./max	AC 10 V; DC 10 V / DC 250 V, AC 400 V (AC/DC 2 V / AC/DC 60 V) ¹⁾		
2.4 Limit. contin. current I _{th} max. (each contact)	8 A		
Switching current min./max	10 mA ²⁾ / 8 A (2 mA / 0.3 A) ¹⁾		
2.5 Switching power min./max.	0,1 VA ²⁾ / 2000 VA (10 mVA / 12 VA) ¹⁾		
Switching power min./max	0,1 W ²⁾ ... 200 W (10 mW / 12 W) ¹⁾ (see arc limit curve under resistive load)		
2.6 Switching capacity to IEC/EN 60947-5-1			
AC 15 ³⁾	NO: AC 250 V / 3 A	NC: AC 250 V / 1 A	
AC 15 ⁴⁾	NO: AC 250 V / 5 A	NC: AC 250 V / 2 A	
DC 13 ³⁾	NO: DC 24 V / 2 A	NC: DC 24 V / 2 A	
DC 13 ³⁾ at 0,1 Hz	NO: DC 24 V / 4 A	NC: DC 24 V / 4 A	
to UL 508	B300 / R300		
2.7 Electrical life	> 10 ⁶ switching cycles		
at AC 230 V, 8 A, cos ϕ = 1	At 1 s On, 1 s Off (see diagram)		
2.8 Switching frequency max.	20 switching cycles/s		
2.9 Response time / Release time	Typically 10 ms / Typically 5 ms		
2.14 Contact gap	> 0.5 mm ⁵⁾		
3.0 Other			
3.1 Mechanical life	> 40 x 10 ⁶ switching cycles		
3.2 Temperature range	- 40 ... + 85 °C		
3.3 Degree of protection	Wash proof RT III		
3.4 Test procedure	A (group mounting)		
3.5 Vibration resistance	10 ... < 60 Hz; 0,35 mm Amplitude IEC/EN 60068-2-6 60 ... 200 Hz, \leq 5g (all contacts) IEC/EN 60068-2-6		
3.6 Climate resistance	040 / 085 / 21; A / B / D IEC/EN 60068-1		
3.7 Short circuit strength	1 kA / AC 250 V IEC/EN 60947-5-1 ³⁾⁴⁾		
SCPD / Fuse	NO contacts: 10 A gG / gL / NC contacts: 6 A gG / gL IEC/EN 60269 ³⁾⁴⁾		

¹⁾ Values for AgNi-contacts + 5 μ m Au

²⁾ Typical values for AgNi and AgSnO₂

³⁾ Values for AgNi

⁴⁾ Values for AgSnO₂

⁵⁾ Over entire service life acc. to DIN EN 61810-3

Technical Data

3.8	Insulation according to IEC 60664-1			
	Rated insulation voltage		AC 250 V	
	Pollution degree		2	
	Overtoltage category		III	
	Test voltage			
	Contact- Coil (1 min)		≥ AC 4 kV eff.	
	Contact - Contact (1 min)		≥ AC 4 kV eff.	
	Contact open (1 min)		≥ AC 1.5 kV eff.	
	Transient voltage			
	Contact- Coil (1,2 - 50 μs)		≥ 6 kV	
	Contact - Contact (1,2 - 50 μs)		≥ 6 kV	
	Clearance and creepage distances			
	Contact- Coil		≥ 5.5 mm	
	Contact - Contact		≥ 5.5 mm	
3.9	Weight	Approx. 14 g	Approx. 15 g	Approx. 16 g
4.0 Packing				
4.1	On cardboard in slipcase	32 pieces	28 pieces	20 pieces
4.2	In case package	320 pieces	280 pieces	200 pieces
5.0 Solder method				
5.1	Solder method /-temperature /-duration		Wave soldering / 260 °C / 5 s	

Design versions

U _N (DC V)	Voltage range (DC V)	OA 5642		OA 5643		OA 5644		
		R _{Coil} Ω±10%	.16 1NO, 1NC	R _{Coil} Ω±10%	.22 2NO, 1NC	R _{Coil} Ω±10%	.48 3NO, 1NC	.52 2NO, 2NC
AgSnO ₂ -contacts + 0,2 μm Au								
6	4.2 ... 9.6	90	4231	70	4331	55	4431	4531
12	8.4 ... 19.2	370	4232	290	4332	220	4432	4532
21	15.0 ... 33.6	1050	4233	840	4333	680	4433	4533
24	16.8 ... 38.4	1450	4234	1150	4334	900	4434	4534
48	33.6 ... 76.8	6000	4235	4600	4335	3600	4435	4535
60	42.0 ... 96.0	9250	4236	7100	4336	5600	4436	4536
110	77.0 ... 176.0	31000	4237	24000	4337	18500	4437	4537
AgNi-contacts + 0.2 μm Au								
6	4.2 ... 9.6	90	4201	70	4301	55	4401	4501
12	8.4 ... 19.2	370	4202	290	4302	220	4402	4502
21	15.0 ... 33.6	1050	4203	840	4303	680	4403	4503
24	16.8 ... 38.4	1450	4204	1150	4304	900	4404	4504
48	33.6 ... 76.8	6000	4205	4600	4305	3600	4405	4505
60	42.0 ... 96.0	9250	4206	7100	4306	5600	4406	4506
110	77.0 ... 176.0	31000	4207	24000	4307	18500	4407	4507
AgNi-contacts + 5 μm Au								
6	4.2 ... 9.6	90	4221	70	4321	55	4421	4521
12	8.4 ... 19.2	370	4222	290	4322	220	4422	4522
21	15.0 ... 33.6	1050	4223	840	4323	680	4423	4523
24	16.8 ... 38.4	1450	4224	1150	4324	900	4424	4524
48	33.6 ... 76.8	6000	4225	4600	4325	3600	4425	4525
60	42.0 ... 96.0	9250	4226	7100	4326	5600	4426	4526
110	77.0 ... 176.0	31000	4227	24000	4327	18500	4427	4527

Ordering Example

OA 5642... / ... W 1 / 61*)

Pin configuration

W = Wash proof RT III

Design version

Contact arrangement (Type A)

.16 1 NO / 1 NC

*) / 61 cURus approval

Notes

For the use and processing of our PCB relays, please refer to the **application and processing instructions** at www.dold.com

Characteristics

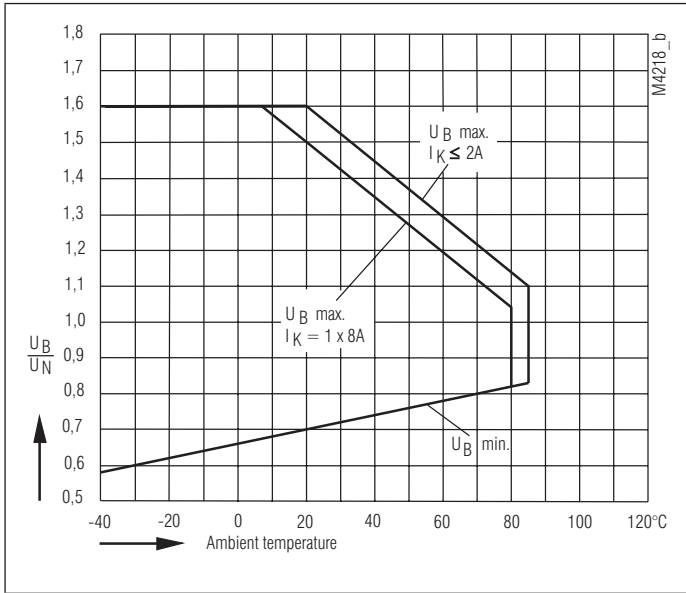

Operating voltage limit curve
OA 5642.16

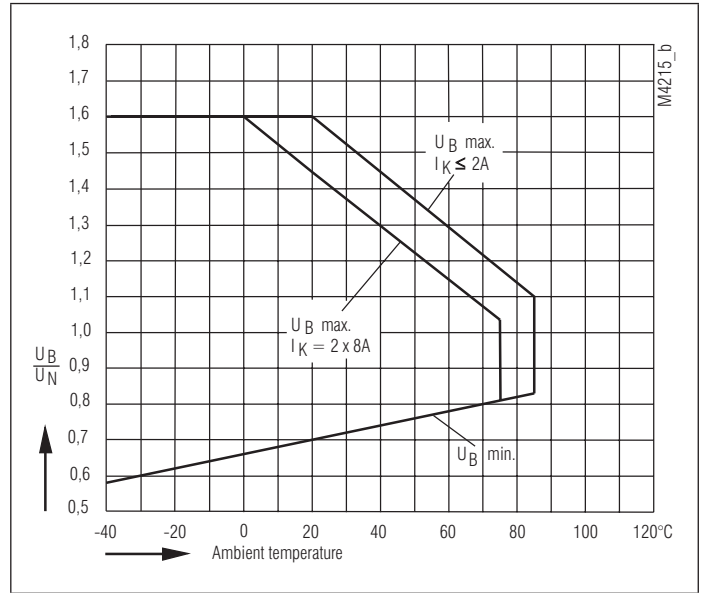

Operating voltage limit curve
OA 5644.52 und OA 5643.22

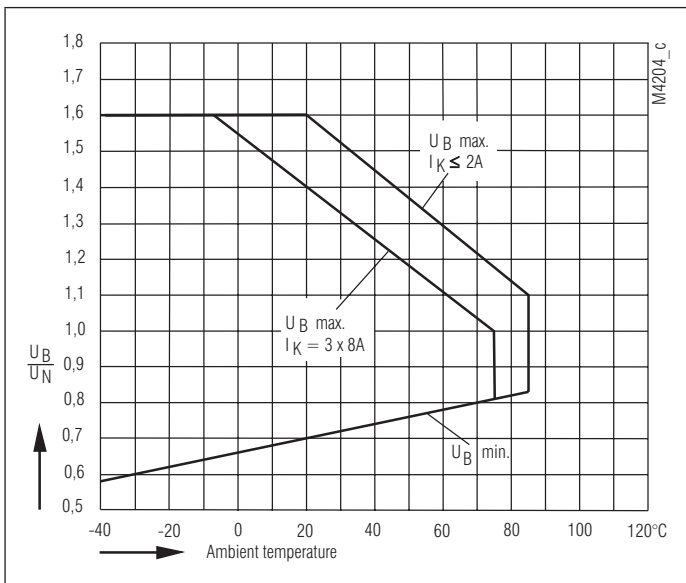

Operating voltage limit curve
OA 5642.48

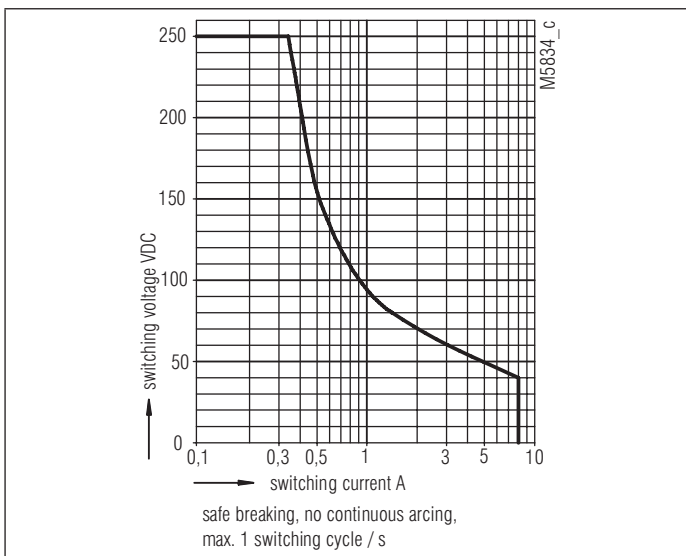

Arc limit curve (load limit curve)

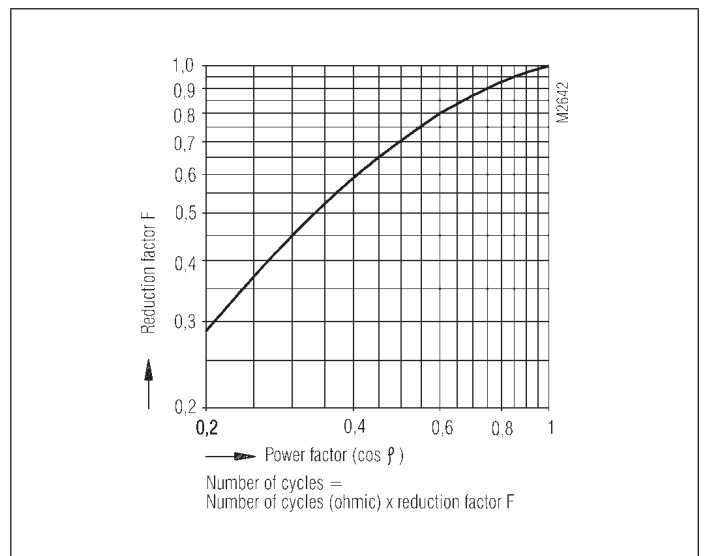

Reduction factor for inductive loads

Electrical life of the output contacts determined by
DIN EN 60947-5-1 / Annex C.3

M4276_d

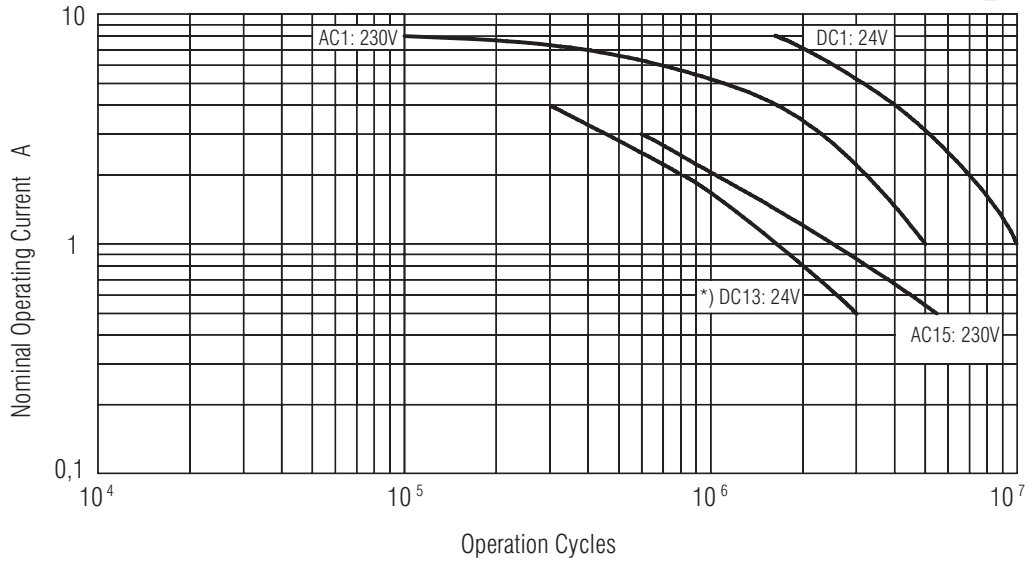

Electrical life for contact material AgNi

*) ≤ 2 A at 0.25 ... 1 Hz
> 2 A ... 4 A bei 0.1 Hz

Electrical life of the output contacts determined by
DIN EN 60947-5-1 / Annex C.3

M20410_a

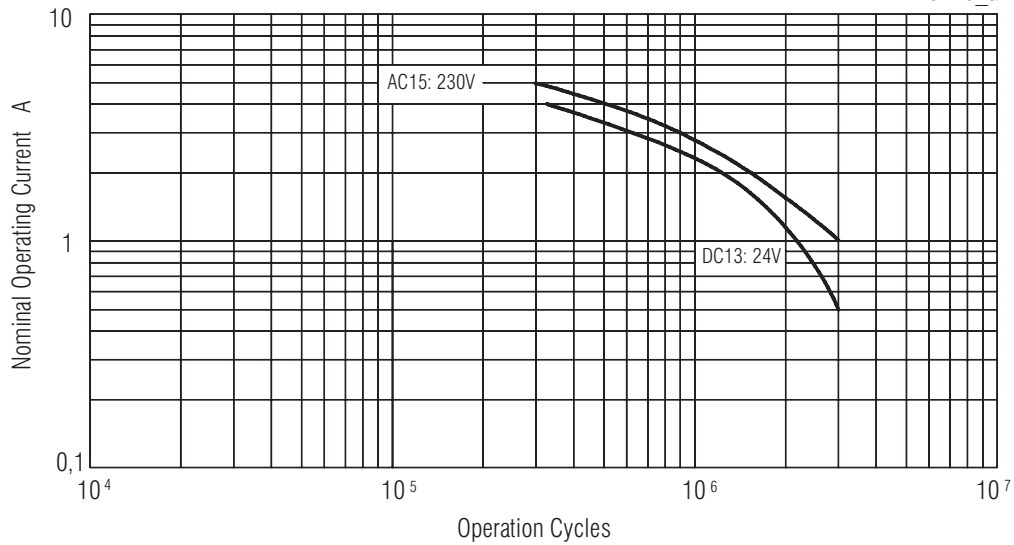

Electrical life for contact material AgSnO

OA 5642 Dimensions, Pin Configuration, Connection Diagrams

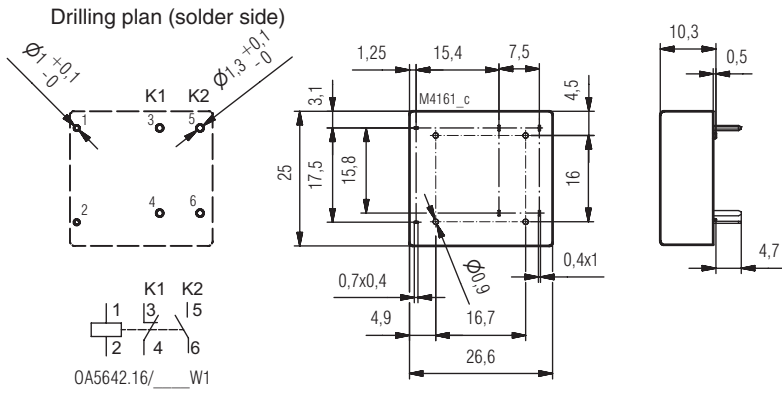

OA 5643 Dimensions, Pin Configuration, Connection Diagrams

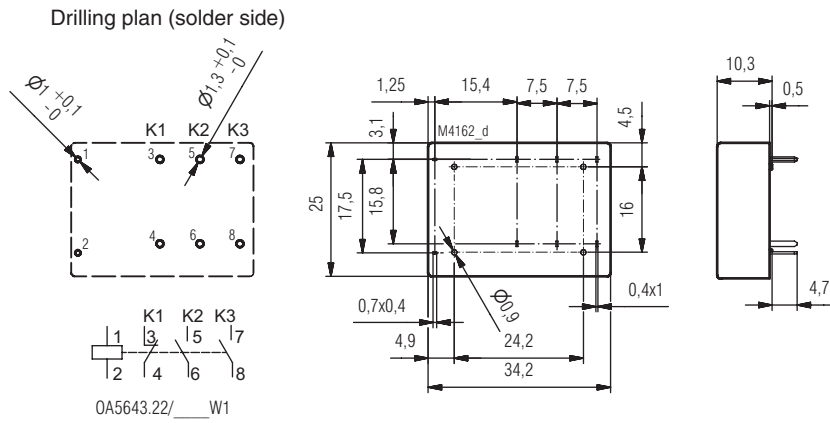

OA 5644 Dimensions, Pin Configuration, Connection Diagrams

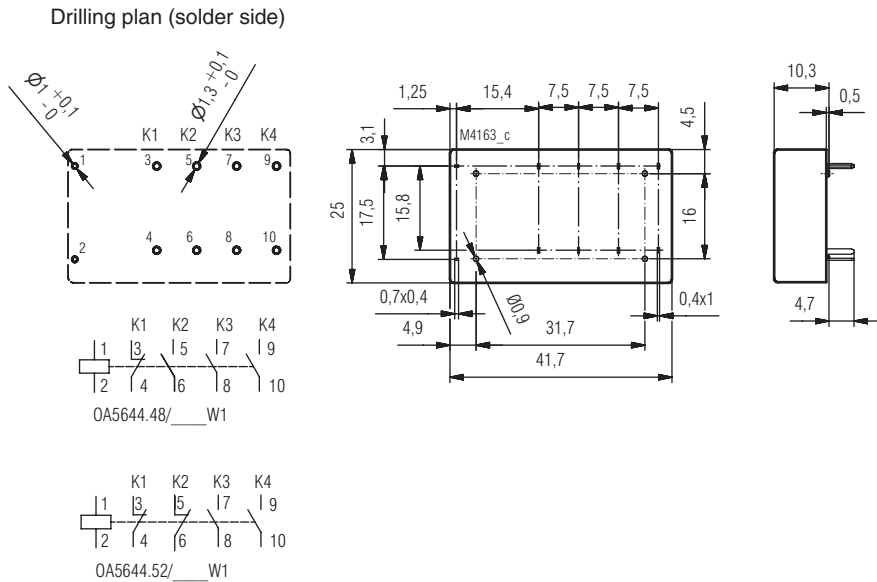

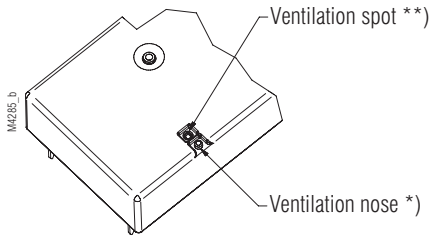

*) When using the maximum switching capacity it is recommended to open the relay at the indicated position.

***) During the reflow solder process the relay is open at the ventilation spot. For more information see additional information sheet.

A large grid of graph paper. The grid consists of 20 columns and 30 rows. The grid lines are composed of solid and dotted lines in an alternating pattern. The first vertical line and every second vertical line are solid. The first horizontal line and every second horizontal line are solid. This creates a pattern of solid and dotted lines that forms a grid suitable for technical drawing or engineering.

A vertical column of horizontal lines on the right side of the page, intended for writing. It consists of 30 horizontal lines, one for each row of the grid, providing a space for notes or calculations.

